

# Pilot's Information Manual

# SYSTEM TWENTY SYSTEM THIRTY SYSTEM THIRTY ALT Autopilots



**S-TEC Corporation**

For Information Only-Not approved for cockpit use.

**List of Effective Pages**

\*The asterisk indicates pages changed, added, or deleted by current change.

--

**Record of Revisions**

Retain this record in the front of the manual. On receipt of revisions, insert revised pages in the manual, and enter date inserted and initials

REVISION NUMBER	REVISION DATE	INSERTION DATE/BY	SB NUMBER INCLUDED
1 <sup>st</sup> Edition	10 Feb, 1999		

# Table of Contents

Introduction and FAA Notice	4
Pictorial Diagrams of the Twenty/Thirty/ThirtyALT Systems	5
List of Applicable Acronyms	8
System Twenty Modes of Operation	9
System Twenty Functional Preflight Procedures	12
System Twenty In Flight Operating Procedures	14
Approach and Tracking Pictorials	16
System Thirty Modes of Operation	20
System Thirty Functional Preflight Procedures	21
System Thirty In Flight Operating Procedures	22
System ThirtyALT Modes of Operation	23
System ThirtyALT Functional Preflight Procedures	24
System ThirtyALT In Flight Operating Procedures	25
Basic Emergency Procedures	26
System Specifications	28

# Introduction

The primary purpose of the System Twenty/ Thirty/ ThirtyALT **Pilot Operating Handbook (POH)** is to provide pilots with step-by-step Functional Preflight and In Flight Operating procedures for the installed system.

## Notice

**This material may be used in conjunction with FAA approved Airplane Flight Manual Supplement (AFMS) Pilots Operating Handbook Supplement (POHS) or Supplemental Flight Manual (SFM). Refer to the specific AFMS, POHS, or SFM for your aircraft specific information and emergency operating procedures.**

**If the autopilot is to be used during Instrument Flight Rules (IFR) operations, we recommend that you develop a thorough understanding of the autopilot system, its functions, and characteristics in Visual Meteorological Conditions (VMC). Accomplish this before undertaking a Visual Flight Rules (VFR) flight.**

# SYSTEM TWENTY

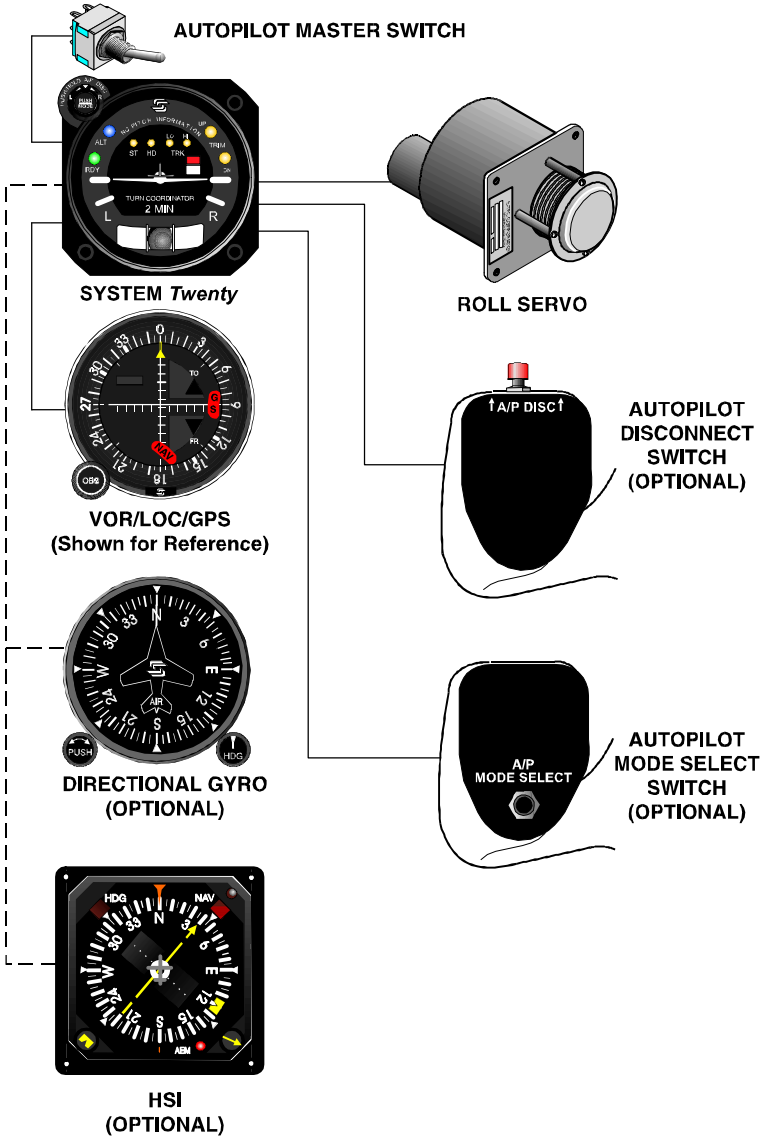

# SYSTEM THIRTY

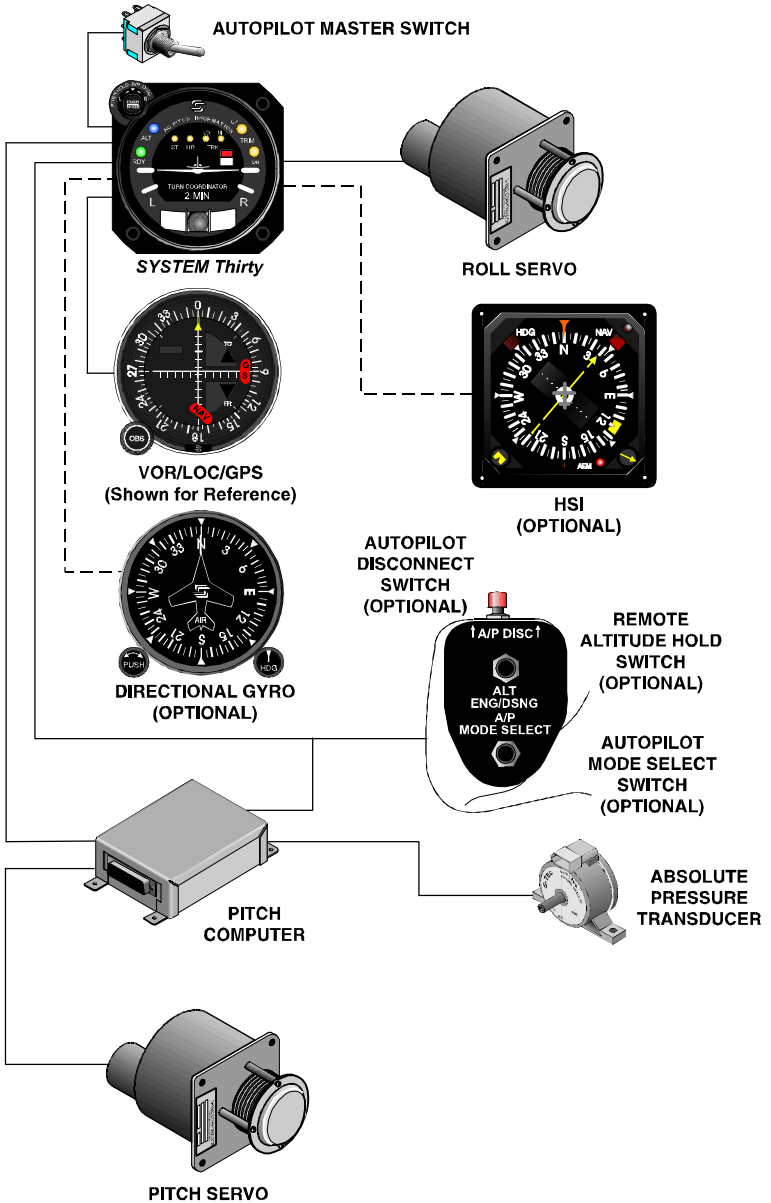

# SYSTEM **THIRTY**ALT

System *Thirty*ALT

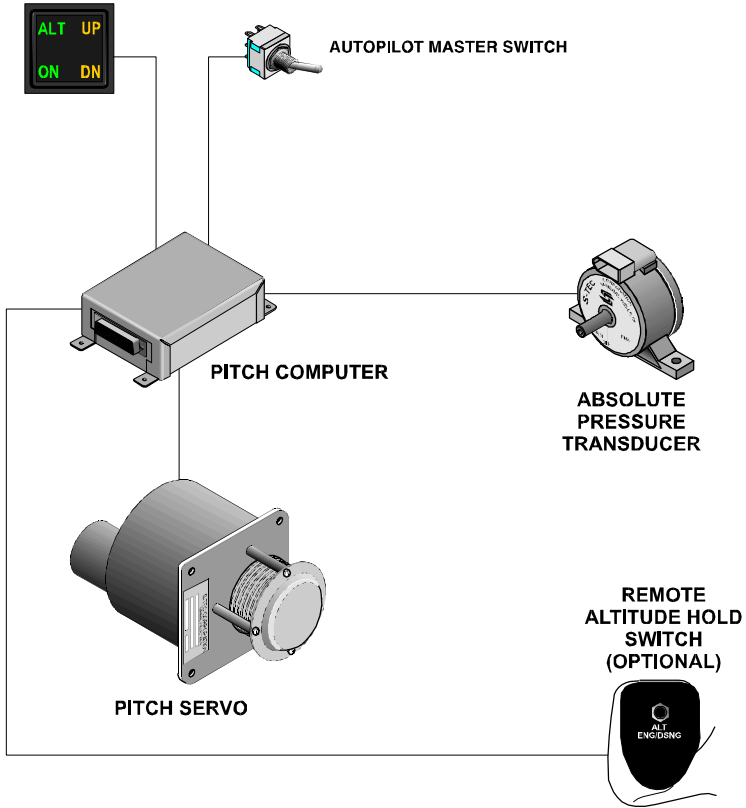

## Acronyms Used in This Manual

ALT	Altitude
AFMS	Airplane Flight Manual Supplement
A/P	Auto Pilot
CB	Circuit Breaker
CDI	Course Deviation Indicator
CWS	Control Wheel Steering
DG	Directional Gyro
FAA	Federal Aviation Administration
GPS	Global Positioning System
HD	Heading
Hg	Mercury
HSI	Horizontal Situation Indicator
HI-TRK	High Gain Tracking
IFR	Instrument Flight Rules
IFP	In Flight Procedures
IMC	Instrument Meteorological Conditions
LOC	Localizer
LORAN	Long Range Navigation
LO-TRK	Low Gain Tracking
NAV	Navigation
OBS	Omnibearing Selector
POH/(S)	Pilot Operating Handbook/(Supplement)
PSI	Pounds Per Square Inch
RDY	Ready
SFM	Supplemental Flight Manual
ST	Stabilizer
TSO	Technical Standard Order
VFR	Visual Flight Rules
VMC	Visual Meteorological Conditions
VOR	Very High Frequency Omnidirectional Radio Range



# Twenty/Thirty/ThirtyALT

## System Twenty Modes of Operation



1. The System Twenty provides the aircraft with Roll Axis control only.
2. The Turn Coordinator contains the Roll Computer, Rate Gyro, Autopilot pick-off, Rate Gyro RPM detector, and an instrument power monitor that will flag if low system voltage occurs.
3. The System Twenty Turn Coordinator receives power through the battery buss and connects through an existing circuit breaker (CB) such that the basic Turn Coordinator function is powered on application of aircraft power. With adequate power applied, the Red Flag in the face of the unit fully retracts, indicating the Turn Coordinator function is operational.
4. A separately mounted On/Off panel switch and an A/P CB provides Integrated Roll Computer power. Power to the A/P CB can be supplied through the Avionics Master Switch. When activated a self-test is completed. The Functional Pre-Flight section contains this procedure.
5. The Rate Gyro is the basic sensor for roll stabilization.

6. The Rate Gyro signal combines with, the Turn Command Knob, Heading Error Signal, or NAV inputs to generate a Roll Error signal, which then drives the roll servo as needed.
7. The System Twenty operates in one of four roll modes. The modes are Stabilizer, Heading, Low Track, and High Track, the latter two being navigation modes.
8. The green Ready (RDY) Light indicates the gyro has reached its operating RPM and the autopilot can be engaged.
9. The multi-functional Push Mode Select Knob, with each push, engages any one of the four autopilot modes sequentially. Depress and hold it until the A/P disconnects.



10. In the Stabilizer Mode (ST), the Mode Select Knob, when centered, holds the wings level. When turned left or right it sends a proportional turn command to the roll servo. It activates the turn command for roll axis maneuvers up to 90% of a standard turn rate. The turn command function is inactive in HD, LO-TRK, and HI-TRK modes.



11. Heading Mode requires an optional Directional Gyro (DG) or Horizontal Situation Indicator (HSI) with compatible outputs. The heading bug permits pre-selected heading turns and heading hold. If the System Twenty is not interfaced to an autopilot compatible DG or HSI the autopilot will by-pass this mode and advance to the "LO-TRK" mode.



12. LO-TRK Mode is primarily for VOR cross-country navigation. The low gain minimizes autopilot response to needle deviations. This will prevent over-correction in areas where low elevation or extreme distances from a VOR cause the needle to become noisy or have a scalloping effect.



13. The HI-TRK Mode is designed for Localizer approaches, GPS/LORAN tracking, and a more aggressive NAV tracking such as VOR approaches.
  14. The aircraft lighting rheostat controls the A/P systems light intensity.
- 
- 

## System Twenty

### Functional Preflight Procedures

**Note:** There must be adequate aircraft DC voltage (14 or 28 Vdc) to perform these checks. Low voltage may adversely effect the Functional Preflight Procedures

1. Autopilot master switch "ON". RDY, ST, HD, LO TRK, and HI TRK lamps will temporarily illuminate on the annunciator panel. After 7 seconds, all lamps will be out. After 1-2 minutes the green "RDY" light illuminates indicating the autopilot can be engaged.
2. Press and release the Mode Select Knob, "ST" lamp illuminates. Rotate turn knob left then right, observe that the control wheel moves respectively. Center the Mode Select Knob. The control wheel should remain motionless.

3. Set the DG (if installed) and place heading bug under the Lubber line. Press and release the Mode Select Knob, "HD" lamp illuminates. Rotate heading bug left then right, observe the control wheel moves respectively.
4. Override Test, grasp the control wheel and slowly overpower the roll servo left and right to ensure proper clutch action.

**Caution:** Control wheel movements should be smooth. If any unusual noise or feel occurs immediately inspect the installation and the clutch settings and repair as needed. **Do not operate the Autopilot under these conditions.**

5. Radio Check, tune the Nav radio to a valid VOR signal. Press and release Mode Select Knob, LO-TRK lamp illuminates. Move VOR OBS so the CDI needle moves left and right. Observe that the control wheel moves respectively. Press and release Mode Select Knob, HI-TRK lamp illuminates. Perform the same test. The control wheel response should be slightly faster in this mode.
6. Press and hold the Mode Select Knob until the A/P disconnects. Repeat this test using the optional control wheel mounted A/P disconnect switch, if installed. As the autopilot disconnects, the "RDY" light flashes with a five-second audible beeping tone.

## System Twenty In Flight Procedures

### Stabilizer and Heading Mode

1. Check that the "RDY" light is ON.
2. Trim aircraft to desired flight conditions.
3. Center Mode Select Knob, press and release to engage the "ST" mode.
4. Set the Mode Select Knob as desired for level flight or turns.
5. Set the heading bug (if installed) to a desired heading, press and release the Mode Select Knob to engage "HD".

### VOR Tracking and VOR Approach

**Note:** The System Twenty/Thirty does not provide intercept capability but will accurately track a reliable navigation signal when following one of these procedures listed below:

1. Tune the NAV receiver, verify a valid Nav Signal, and then select a Radial.
2. Set the A/P NAV select switch to the proper source, if so equipped.
3. Maneuver the aircraft to within  $\pm 1$  needle width and within  $10^\circ$  HDG of the selected radial.
4. Press and release Mode Select Knob until LO-TRK lamp illuminates for VOR cross country or HI-TRK for VOR approaches and more sensitive tracking.

## Localizer Approach

1. Tune the NAV receiver to the desired Localizer frequency.
2. Set A/P NAV select switch to proper source, if so equipped.
3. Maneuver the aircraft to within +/- 1 needle width and within 10° HDG of the published inbound localizer course.
4. Press and release Mode Select Knob until HI-TRK lamp illuminates.

## GPS Tracking and GPS Approach

1. Enter desired waypoint in GPS receiver.
2. Set A/P NAV select switch to proper source, if so equipped.
3. Maneuver the aircraft to within +/- 1 needle width and within 10° of the course displayed on the GPS receiver.
4. Press and release Mode Select knob until HI-TRK lamp illuminates.

**Note:** This procedure is also applicable with Loran.

**Note:** When flying multiple waypoints repeat steps 3 &4 for each leg if it involves more than a 10° course change.

# Procedure Turn Localizer Approach and Tracking, Standard D.G.

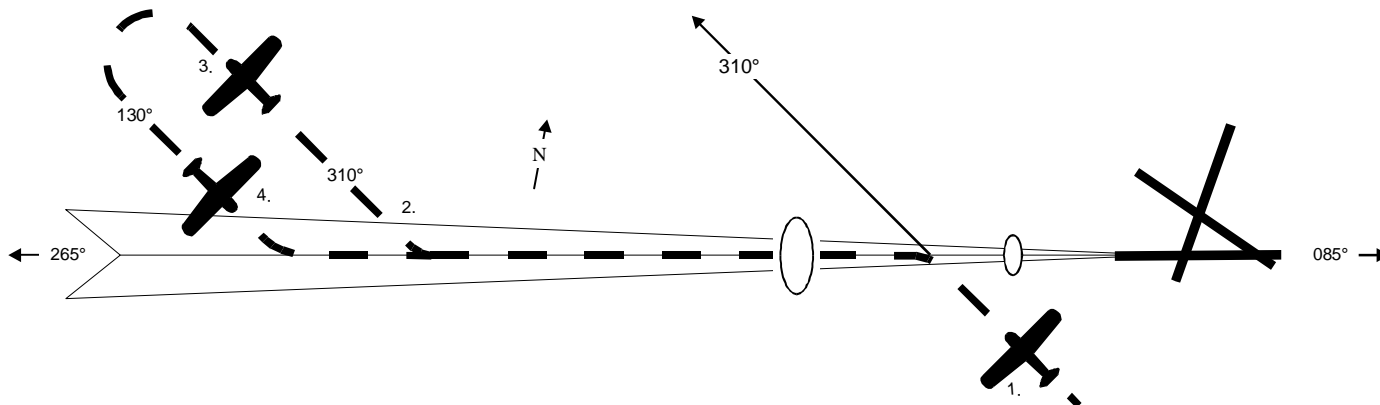

1. **A.** Tune navigation radio to LOC frequency.  
**B.** Set heading bug to published outbound LOC heading. Select HDG Mode.
2. **A.** Set heading bug to outbound procedure turn heading.
3. In 90° increments, set heading bug to *inbound* procedure turn heading.
4. **A.** Set heading bug to inbound LOC heading.  
**B.** Select the HI-TRK mode. Autopilot will track inbound to the airport.  
**C.** Once established in HI-TRK mode, set heading bug to the published missed approach heading.

### Note

Before engaging HI-TRK be sure the aircraft is on course within  $\pm 1$  needle width and within  $\pm 10^\circ$  of HDG of the inbound course

### Note

If a missed approach is declared at the middle marker:

2. **A.** Disconnect the autopilot and stabilize the aircraft for the missed approach.  
**B.** Select the HDG mode.



# Straight In Localizer Approach and Tracking, Standard D.G.

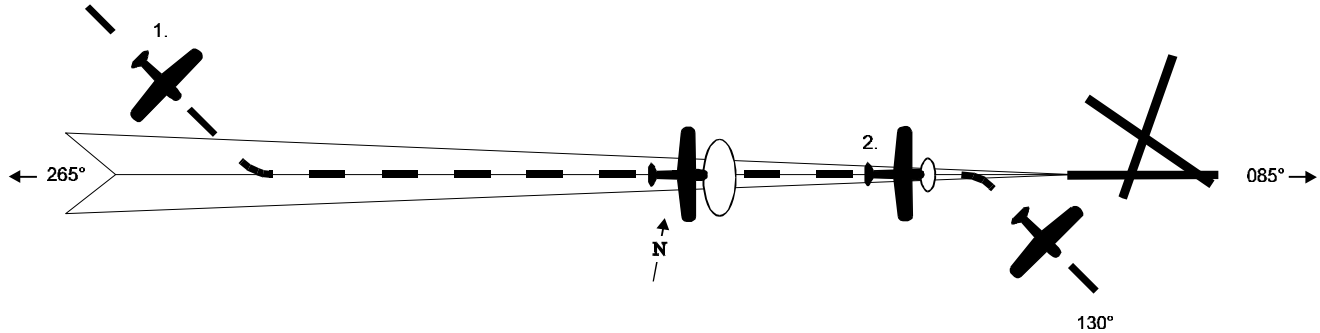

1. **A.** With HDG Mode selected, tune navigation radio to localizer frequency.  
**B.** With HDG bug, position aircraft on the Localizer inbound course.  
**C.** Select the HI-TRK mode. Autopilot will track inbound to the airport.  
**D.** Once established in HI-TRK mode, set heading bug to the published missed approach heading.

## Note

Before engaging HI-TRK be sure the aircraft is on course within  $\pm 1$  needle width and within  $\pm 10^\circ$  of HDG of the inbound course

## Note

If a missed approach is declared at the middle marker:

2. **A.** Disconnect the autopilot and stabilize the aircraft for the missed approach.  
**B.** Select the HDG mode.

# Procedure Turn Localizer Approach and Tracking, Optional HSI

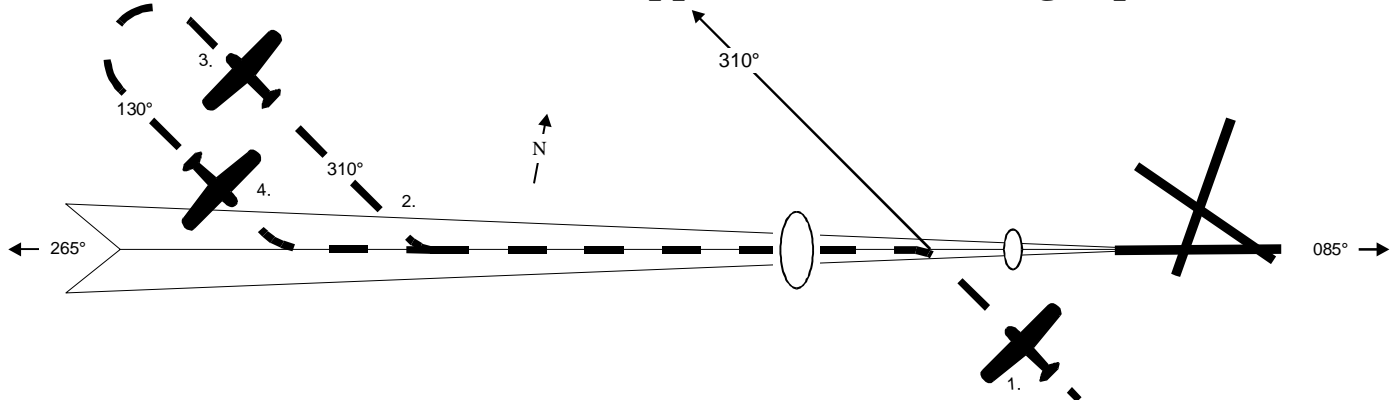

1. **A.** Tune navigation radio to LOC frequency.  
**B.** Set published **inbound** LOC course with course pointer.  
**C.** Set HDG bug to desired HDG for Localizer outbound. Press HDG mode switch.
3. Set HDG bug to published outbound procedure turn HDG.
4. **A.** In 90° increments, set heading bug to inbound procedure turn heading.  
**B.** When established on inbound course to the airport select HI-TRK mode.  
**C.** Once established in HI-TRK mode, set heading bug to the published missed approach heading.

### Note

Before engaging HI-TRK be sure the aircraft is on course within  $\pm 1$  needle width and within  $\pm 10^\circ$  of HDG of the inbound course

### Note

If a missed approach is declared at the middle marker:

2. **A.** Disconnect the autopilot and stabilize the aircraft for the missed approach.  
**B.** Select the HDG mode.

# Straight In Localizer Approach and Tracking, Optional HSI

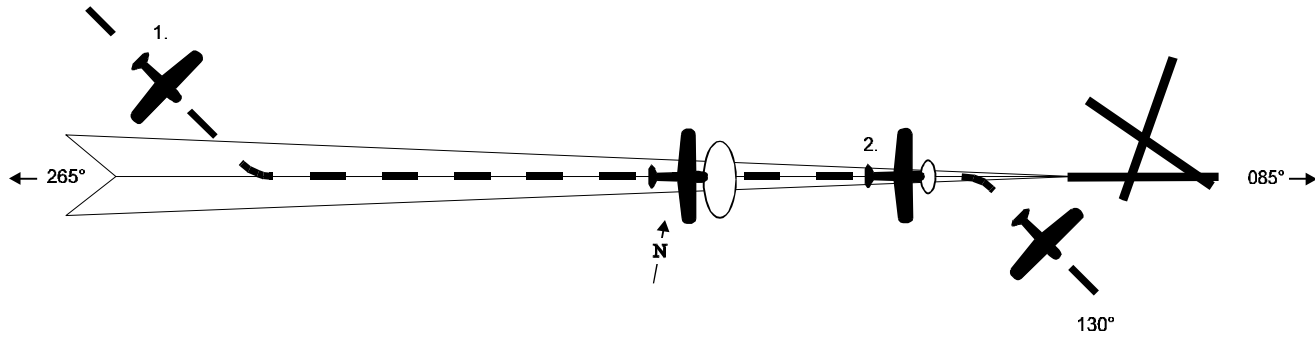

1. **A.** With the HDG Mode selected, tune navigation radio to LOC frequency.  
**B.** With the HDG bug, position the aircraft on the Localizer course.  
**C.** Select HI-TRK mode. The A/P will track inbound to the airport.  
**D.** Once established in HI-TRK mode, set heading bug to the published missed approach heading.

## Note

Before engaging HI-TRK be sure the aircraft is on course within  $\pm 1$  needle width and within  $\pm 10^\circ$  of HDG of the inbound course

## Note

If a missed approach is declared at the middle marker:

2. **A.** Disconnect the autopilot and stabilize the aircraft for the missed approach.  
**B.** Select the HDG mode.

## System Thirty Modes of Operation

**Note:** The Roll Axis is identical for the System Twenty and System Thirty. Refer to the System Twenty section for Roll Axis procedures.



1. The System Thirty incorporates an accelerometer and absolute pressure transducer as pitch rate sensors.
2. The Dynamic Acceleration, Vertical Speed, and Altitude Error Signals combine to obtain the Pitch Error Signal, which then drives the pitch servo as needed.
3. Altitude Hold Mode, the Altitude Hold light (blue), located above the green "RDY" light illuminates when Altitude Hold engages.
4. Trim Up light indicates the aircraft is out of trim nose down and requires elevator "UP" trim.
5. Trim Dn light indicates the aircraft is out of trim nose up and requires elevator "DOWN" trim.
6. With both lights out the aircraft is in trim.
7. The aircraft lighting rheostat controls the A/P systems light intensity



## System Thirty Functional Preflight Procedures

**Note:** Refer to the System Twenty Preflight for Roll Command checks.

1. Autopilot Master Switch "ON"
2. RDY, ST, HD, Lo Trk, HI-TRK, Trim-Up, Trim-Dn, Alt all annunciate.
3. Trim-Up light extinguishes after 2 seconds.
4. All others extinguish after 7 seconds except ALT, which extinguishes after 10 seconds.
5. Engage desired roll mode, move control wheel to the neutral position.
6. Select ALT mode by pressing and releasing the Remote Altitude Hold Eng/Dsng switch. The blue indicator light will illuminate.
7. Slowly apply forward pressure to the control wheel, "Trim-Up" light illuminates and alert tone is audible, release pressure. Light should go out and tone off.

**Note:** Some aircraft have weights in the control system that may apply a FWD pressure when the controls are released. This keeps the "TRIM UP" light illuminated. Applying AFT pressure to the controls during this check will "Unload" this pressure on the system.

8. Slowly pull control wheel aft until the "Trim Down" light illuminates and alert tone is audible, return wheel to neutral. Light should go out and tone is off.
9. Press and release the Alt Hold Eng/Dsng switch, the blue indicator should go out. Verify disengagement of the pitch servo by moving the control wheel fwd and aft.

10. Press and hold the Mode Select switch until the A/P disconnects or the optional control wheel mounted A/P disconnect switch, if installed. The RDY light flashes, you should get an audible beeping tone for approximately five seconds.

---

---

## **System Thirty In Flight Procedures**

**Caution:** If necessary, the required pre-flight test can be conducted in flight. However, during the power up test the pitch servo will engage and disengage to ensure that it will disengage during excessive "G" conditions. **Therefore, do not attempt flight maneuvers during the power up test.**

**Caution:** If the pilot fails to trim the aircraft, the UP or DN trim light will annunciate with an audible alert tone. Within 4 seconds, the trim light will flash and the alert tone will beep.

1. Trim aircraft for level flight conditions, set power, and permit air speed to stabilize, then trim elevator as required.
2. Toggle "A/P" switch "ON"; verify green "RDY" light is illuminated after power on test terminates.
3. Select desired Roll Mode, verify light illuminates.
4. Engage Altitude Hold, verify "ALT" (Blue) indicator light illuminates.
5. Trim elevator according to light indication on the System Thirty controller.
6. In order to climb or descend, disengage the Altitude Hold.

**Note:** If aircraft encounters turbulence, it is normal for the Trim Annunciator Lights to flicker. Elevator trim is only required if the trim Annunciator Light remains on and you hear an alert tone.

**Example:** "Trim Up" indicates the need for nose up trim. The Aircraft is in trim when both lights are out.

# System ThirtyALT Modes of Operation



1. The System ThirtyALT provides aircraft pitch axis control only. The System Thirty and ThirtyALT pitch computers are identical.
2. The Dynamic Acceleration, Vertical Speed, and Altitude Error Signals combine to obtain the Pitch Error Signal, which then drives the pitch servo as needed.
3. Green "ON" and "ALT" lights will illuminate when the ALT Hold switch is engaged on the ALT Hold Push ON/OFF panel. A yellow trim UP or DOWN light will illuminate and a steady audio alert will accompany the trim light after approximately five seconds. If the pilot fails to trim the aircraft, the UP or DN trim light will begin to flash accompanied by a beeping tone to emphasize a need for trim. Both lights are out the aircraft is in trim.
4. Altitude Hold Power comes through the master power switch for the ThirtyALT System. This switch must be ON before the "ALT Hold" switch will function.
5. The control wheel ALT Eng/Dsng switch is an optional switch that permits the pilot to engage or disengage the Altitude Hold from the control wheel, once the master switch has been powered up.
6. The aircraft lighting rheostat controls the A/P systems light intensity

## System ThirtyALT Functional Preflight Procedures

**NOTE:** There must be adequate aircraft DC voltage (14 or 28 Vdc) to perform these checks.

1. Each time the Altitude Hold power is switched on, the system will go through a self-test. All annunciator lights and the integral pitch accelerometer circuitry are tested during this time. The following should occur:
  - a. All lights on the switch should illuminate.
  - b. Trim UP light goes out.
  - c. Trim DN light goes out.
  - d. ALT and ON lights go out.
  - e. The system is ready for engagement after approximately 15 seconds.

**Note:** If the system test fails, the Altitude Hold cannot be engaged, and service is required.

**Caution:** If necessary, the required pre-flight test can be conducted in flight. However, when the trim lights are flashing the pitch servo will momentarily engage and disengage as part of the test. Therefore, avoid flight maneuvers during the test.

2. Center the elevator control and engage the Altitude Hold. Notice that the pitch servo engages.
3. Slowly apply forward pressure on the control wheel, after three seconds the trim UP light illuminates with an audible tone. In approximately five seconds, the trim light flashes and audio beeps until the aircraft is trimmed.
4. Slowly apply aft pressure on the control wheel, after three seconds the trim DN light illuminates with an audible tone.
5. Disconnect the Altitude Hold by pressing the face of the Altitude Hold switch or by using the remote ALT Eng/Dsng switch (if installed) on the control wheel.
6. Verify that the pitch servo has disengaged by moving the control wheel Fwd and Aft.



## **System ThirtyALT In Flight Procedures**

1. Maintain roll axis trim during Altitude Hold operation.
2. Trim aircraft for level flight conditions, set power, and permit air speed to stabilize, then trim elevator as required.
3. Engage ALT Hold by pushing the Altitude Hold switch or the remote ALT Eng/Dsng switch if installed on the control wheel.
4. Trim the elevator according to the trim light indications on the Altitude Hold annunciator panel.
5. Disengage the Altitude Hold for climb or descent modes of flight.

**Note:** If aircraft encounters turbulence, it is normal for the Trim Annunciator Lights to flicker. Elevator trim is only required if the trim Annunciator Light remains on and you hear an alert tone

**Example:** "Trim DN" indicates the need for nose down trim. The Aircraft is in trim with both lights out.

**Note:** If using the ThirtyALT system as a stand alone A/P, without a Roll Axis system, do not use bank angles exceeding Thirty°, excessive altitude losses may occur with the need to retrim the elevator.

## Emergency Procedures

If the aircraft, that has a System Twenty/Thirty/ThirtyALT installed, encounters any malfunctions with the A/P, follow the procedures below.

This information is supplemental to and does not supercede or amend the information provided in the AFMS, POHS, SFM, for specific aircraft and autopilot installation manuals.

If the aircraft does not have a copy of the required AFMS, please call customer service and S-TEC will provide a copy at no cost. Have the aircraft model and type of autopilot when calling for this supplement.

1. In case of an autopilot malfunction, **do not attempt to diagnose the problem in flight.**
2. Immediately regain manual control of the aircraft by overpowering the servo(s) and then disconnect the autopilot system.

**Note:** The system includes a friction override clutch and a disconnect device at each Servo for that purpose. Overpowering the Servo will not damage the system.

3. To disconnect the Autopilot, use one of the following means. Press and release the remote AP disconnect switch on the control wheel (if installed). Press and hold the Mode Select Knob (System Twenty/Thirty only) on the Turn Coordinator/Roll Computer. Move the autopilot master switch to "Off." Pull the autopilot circuit breaker.

4. If improper operation occurs during an instrument approach condition, disconnect the system and fly a manual approach. If a failure occurs inside the final approach fix, it may be desirable to conduct a missed approach, notify Air Traffic Control (ATC) of the problem and fly the approach manually, seeking ATC's assistance as necessary.
5. If a particular mode of operation, including ALT Hold, develops a fault peculiar to that mode only, it is satisfactory to operate the system in other modes as long as a determination can be made as to their satisfactory function.

# Specifications

## System Twenty/Thirty/ThirtyALT

### **Turn Coordinator/Roll**

#### **Computer**

Power required	14/28 Vdc
Flag Voltage Detector limits	9.0Vdc (approx.)
Flag RPM Detector limits	Normal RPM <20%
Current requirements	0.3 Amp
Weight	2.2 lbs.
Dimensions	3.28 x 3.28 x 7.4 in.
TSO	C3d, C9c

### **Directional Gyro**

Power required	Vacuum or pressure, 4.5-5.2 Hg
Minimal air flow	2.2 CFM
Air filtration	3 Micron, 95%
Autopilot pickoff	AC, linear transformer, 5kHz, 8 Vac (pp) supplied by autopilot.
Weight	3.4 lbs.
Dimensions	3.38 x 3.38 x 8.35 in.
Internal lights	14/28 Vdc

### **Roll Servo**

Power required	14/28 Vdc
Current requirements	Included in system requirements
Weight	2.9 lbs.
Dimensions	3.75 x 3.75 x 7.25 in.
TSO	C9c

### **Pitch Computer**

Power required	14/28 Vdc
Weight	1.1 lbs.
Dimensions	5.8 x 1.75 x 3.25 in.
TSO	C9c

**Absolute Pressure  
Transducer**

Power required	10 Vdc,
Pressure range	0-15 PSI Absolute
Overpressure	150% of operating maximum
Weight	0.2 lbs.

**Pitch Servo**

Power required	14/28 Vdc
Current required	Included in system requirements
Weight	2.9 lbs.
Dimensions	3.75 x 3.75 x 7.25 in.
TSO	C9c

**System Current Requirements**

	<u>System</u>	<u>@14Vdc/@28Vdc</u>
Average operating current.	Twenty/Thirty/ ThirtyALT	1.0 Amps/0.5 Amps
Max current	Twenty Thirty ThirtyALT	3.0 Amps/2.0 Amps 5.0 Amps/3.0 Amps 3.0 Amps/2.0 Amps

S-TEC Corporation  
One S-Tec Way • Municipal Airport  
Mineral Wells, Texas 76067-9236 USA  
Telephone 940/325-9406; FAX 940/325-3904  
1-800-USA-STECC  
s-tec.com

The information in this publication is subject to change without notice.

P/N: 8777 Rev. A  
Date: 2 February, 1999  
Printed in USA